

WORKSHOP

H60BASIC

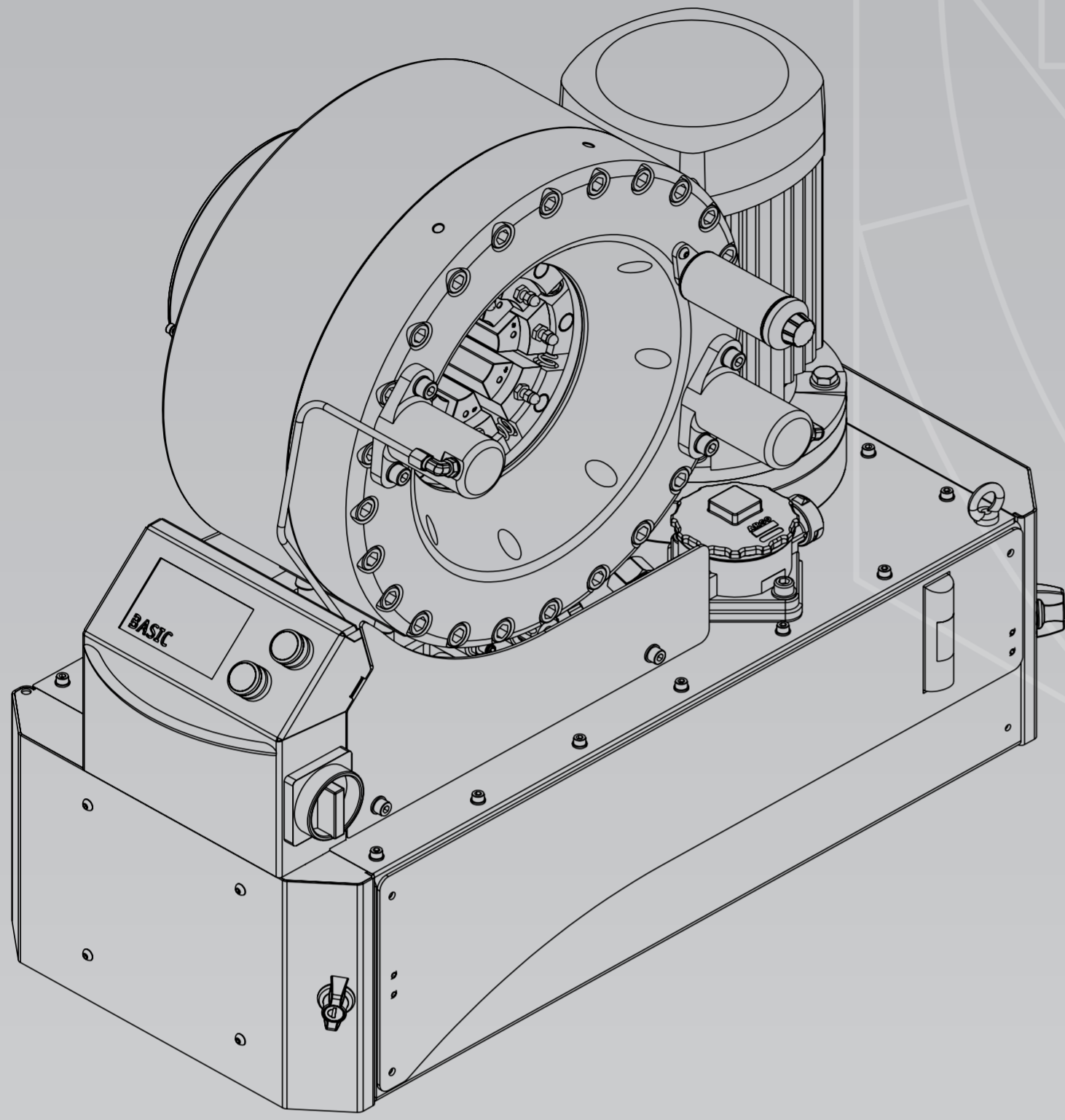

- HOSE SIZE UP TO 4"
- LOW NOISE LEVEL
- 350 TON CRIMPING FORCE
- QUICK TOOL CHANGE

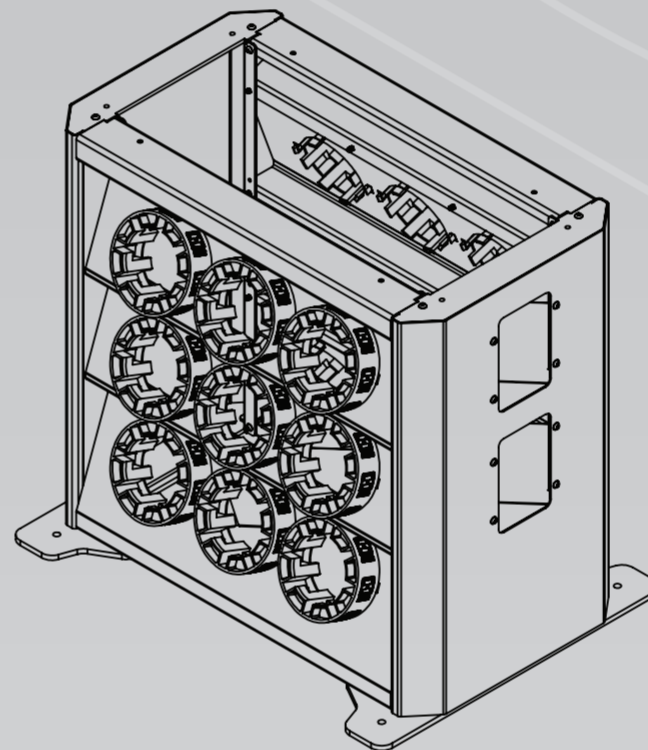

H-Line Crimpers - The solution for the user

Ideal crimper for branch / production facility, that needs to crimp the toughest hydraulic hoses, but also enables crimping of industrial hoses up to 4". All parts are made of high quality steel with rust protective treatment to ensure long lifetime.

TECHNICAL DATA

Crimping range in mm.....	6 - 136
Crimping force in metric tons.....	350
Crimping force in kN.....	3500
Hose size 2SN* (inch).....	4"
Hose size 6SP* (Inch).....	2"
Die Set	H60 / H32
Maximum travel of dies in mm.....	55
Max opening without dies (mm).....	200
Master die Diam. /Length in mm.....	145 /110
Machine control.....	Micrometer Screw
Motor size in kW	5,5
Full open to close in sec.....	10
Full cycle open-close-open in sec.....	14
Noise level dBA.....	69
Oil (l).....	35
Colour.....	Black / Orange

*Hose: 2" IsoBar 350 CO Rock X-Flex - 6SP- High Pressure Hose.
Ferrule: 2" - 4700 Serie.
*Tougher hose can be crimped.

DIES AND PART NUMBER

H32-06.....	9060-32-06
H32-07.....	9060-32-07
H32-08.....	9060-32-08
H32-09.....	9060-32-09
H32-10.....	9060-32-10
H32-12.....	9060-32-12
H32-14.....	9060-32-14
H32-16.....	9060-32-16
H32-19.....	9060-32-19
H32-22.....	9060-32-22
H32-26.....	9060-32-26
H32-30.....	9060-32-30
H32-34.....	9060-32-34
H32-39.....	9060-32-39
H32-45.....	9060-32-45
H32-51.....	9060-32-51
H32-57.....	9060-32-57
H32-63.....	9060-32-63
H32-69.....	9060-32-69
H32-74.....	9060-32-74
H32-78.....	9060-32-78
H60-86.....	9060-60-86
H60-94.....	9060-60-94
H60-102.....	9060-60-102
H60-110.....	9060-60-110
H60-118.....	9060-60-118
H60-128.....	9060-60-128

DESIGNATION AND PART NUMBER

H60BASIC.....	9028-04-03
STAND H60.....	9028-04-01
QC TOOL H32.....	9028-00-09
MECHANICAL BACKSTOP.....	9028-02-11

DIMENSIONS

Width/ Depth/ Height.....	890x490x800 mm
Weight.....	305 kg

